

Lap Robe #1:

Fabric:

Cut 7" Squares washable cotton or flannel fabric. Make 7 rows with 6 squares each in each row. Flame resistant is best. You will need one piece at least 40" x 60" fabric for the back

- 1) Make 7 rows with 6 squares each in each row.
- 2) Piece together with $\frac{1}{4}$ to $\frac{1}{2}$ inch seams. Be sure to sew securely.
- 3) Add polyester lining
- 4) Bind with seam binding or turn the edge of backing to form binding.
- 5) Tie or quilt to finish

Finished Size:

40" x 60"

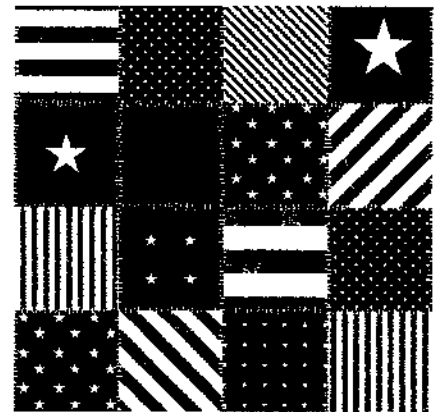
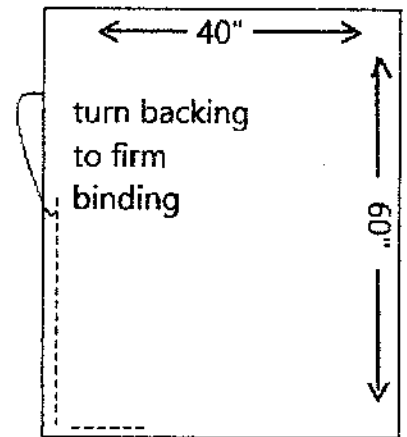

Lap Robe #2:

Sewn Lap Ropes: Size 3' x 5' made of all cotton washable material. Layer of flannel between 2 layers of cotton percale sheets or other cotton material.

Twin Size Quilts:

Twin quilts are used at all Veteran's homes by the residents as their personal bed cover. Twin and $\frac{3}{4}$ size are 70" x 90". There are many wonderful patterns to make. The veterans especially like the patriotic ones. Wildlife and outdoor themes are also good.

Patriotic "End of Life quilt is used by residents in hospice care and remains with the resident or family until the end of their life. It is a touching tribute to their contribution and a way to say Thank you.

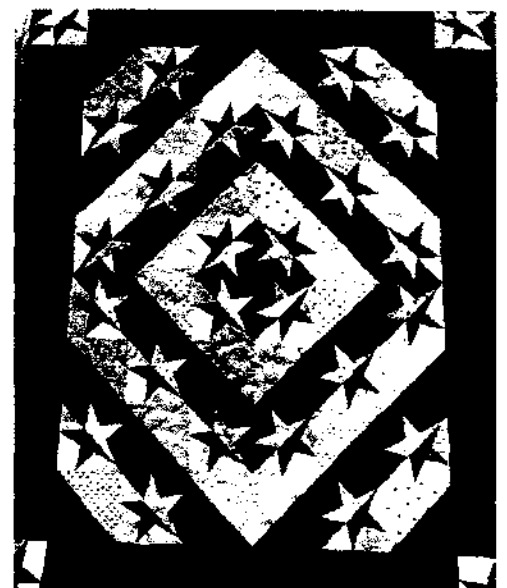

No Sew Fleece Blanket Pattern:

Fabric:

Two coordinating pieces of any fleece

- Baby or Toddler Blanket takes 1-1 ½ yards for each side
- Child takes 1 ¾ Yard for each side
- Teen or Adult takes 2 yards for each side

Hints:

- Fabric is usually 54" or greater.
- Double check that your two pieces of fabric are the same size
- Fleece panels look nice but be sure there is enough material at the edge to cut fringe without cutting into pattern
- Watch for sales at your fabric store, you can save more than 50%

Notions:

- Pair of good scissors or rotary cutter and mat
- Ruler or tape measure

Directions:

- 1) Cut off salvage edge on both sides, keeping you edges as straight as possible.
- 2) Lay fleece wrong sides together, with edges matching up. (Fleece sometimes is hard to tell the right side from wrong side. **You may pin the layers together.
- 3) Cut a 4x4 inch square (or 5x5 inch for longer fringe) out of each corner (through Both layers of fleece.
- 4) Cut 4inch (or 5 inch) at 1inch intervals around all four sides. Tie overhand knot Close to blanket edge then tie again. Repeat around all four sides. Make sure you have two tight, overhand knots for your fringe

Special Notes:

- 1) Use a tape measure across the top of your 4" section to help you make the cuts 1" apart but also only 4" Deep.
- 2) For a more even look, tie every other one all around the blanket, flip the blanket and tie the rest.
- 3) Fleece is very stretchy, so be gentle when tying the edges (especially the selvage) so fringe isn't stretched out of shape.

No Sew Single Layer: Single layer lap robe can be made the same way using only One piece of fleece fabric.

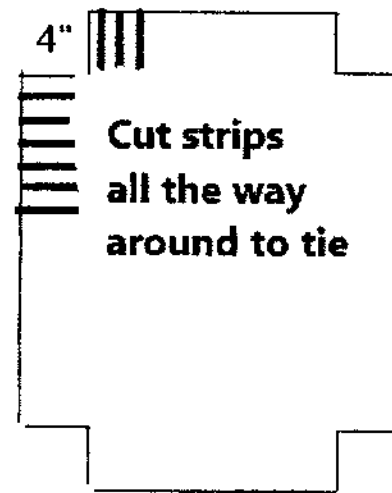

Weighted Lap Pads:

Plastic Pellets:

1). Using Plastic Pellets, fill 4" baggies (candy bags work well) with $\frac{1}{2}$ - $\frac{3}{4}$ Cup of pellets. Fold baggie closed and seal. Twenty-eight (28) filled baggies. Each weighing 3-4 oz. will make a 5-7 lb. lap pad.

(Victory Pellets ordered through Amazon (50#/\$113.00) are machine washable and dryable. Made in USA!)

Fabric:

Use "Blue Trigger" fabric or similar 60" wide durable fabric. Cut 18 inches across salvage to salvage.

2) Sew up the sides (pillowcase style) and turn right side out

3) Make 4 columns by top stitching, even rows, parallel to side seams.

4) Insert a baggie (from Step 1) into each column.

5) Push tight, use straight pin to hold in place. Sew across the row containing the 1st of 7 rows of pellets.

6) Repeat 6 more times.

7) After final 7th row, fold over the salvage edge to create hem.

Weighted Lap Pad is complete.

Create a covering to enclose the Lap Pad:

Using soothing, washable fabric (Polar Fleece or flannel)

Option 1) Close by stitching a 6" piece of Hook/Loop fastener to edge of covering."

Option 2) Cut fleece (or flannel) 18", salvage to salvage, creating 18" x 60" piece.

With right side facing up, fold over 9"- 10" 'salvage', then fold 25" from other edge. Stitch long 25" edges. Turn right side out to expose pocket created with 9"- 10" first fold. No Hook/Loop needed with this option.

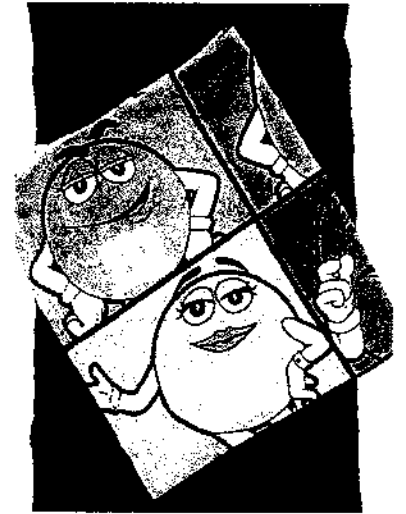

Note: Check with Facility before delivery, as some facilities are NOT using due to Weighted Lap Pad simulates as "restrictive measure".

Draw String Laundry Bag:

Fabric:

The laundry bag is made from 1 yard of 45" sturdy fabric (trigger) with a draw string at the top.

Draw String:

Use paracord or cotton clothesline for the draw string.

Sewing Directions:

1) Fold fabric in half sewing the 36" side and across the bottom. Seams should be reinforced.

2) Sew a 1 1/2" Hem on open edge to form casing for drawstrings. Insert drawstring.

Finished Size:

The completed size will be approximately 25" x 36" when lying flat.

Note:

These bags are given to indigent and homeless Veterans for their use in transporting their personal belongings.

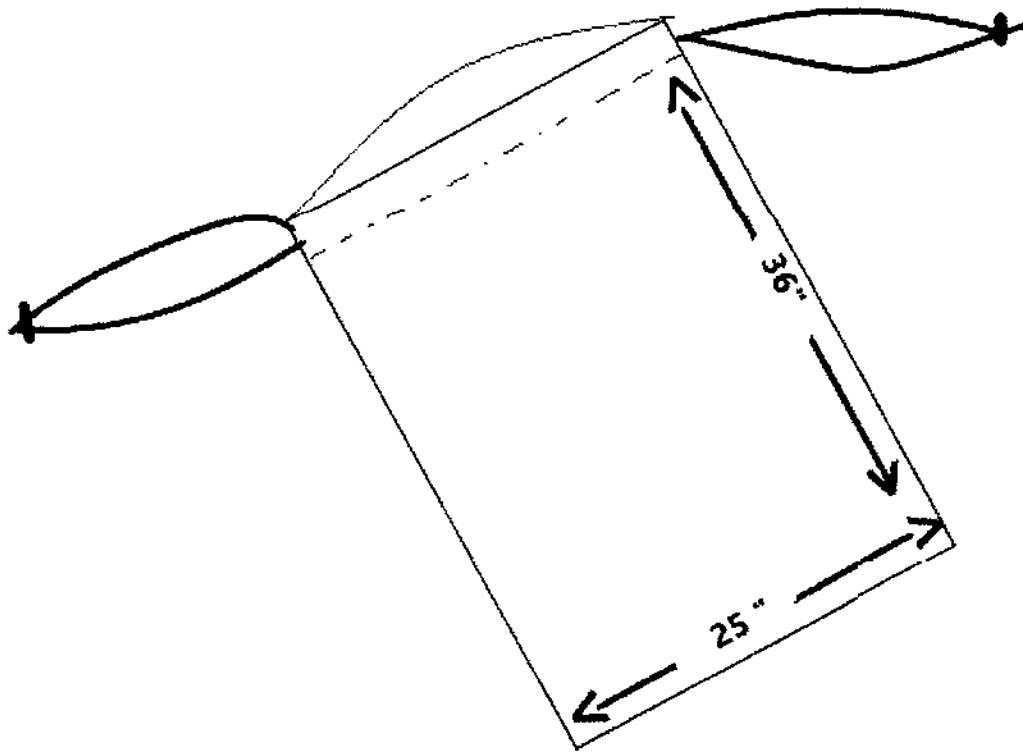
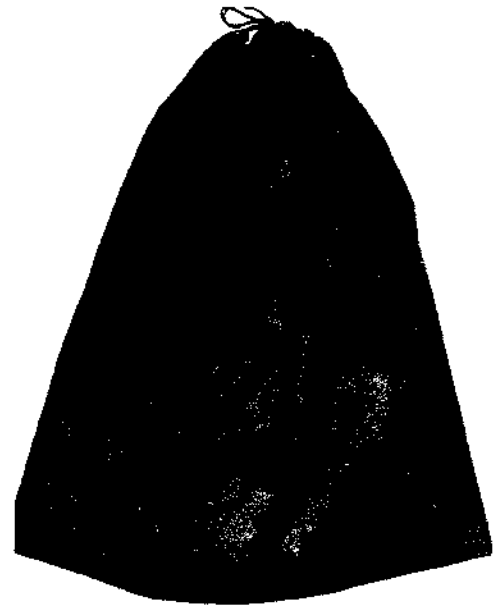

Small Tote Bag:

(10" x 12" for personal items)

Fabric:

These bags can be made from the "trigger" fabric available from Department or use a colorful percale/calico. Material should be sturdy to withstand daily wear and tear.

Finished size is 12" x 10" with a draw string at the top. One tie from each side of bag makes it easier to carry. Ties should be long enough for a large hand. A pair of 32" shoelaces work well for the ties.

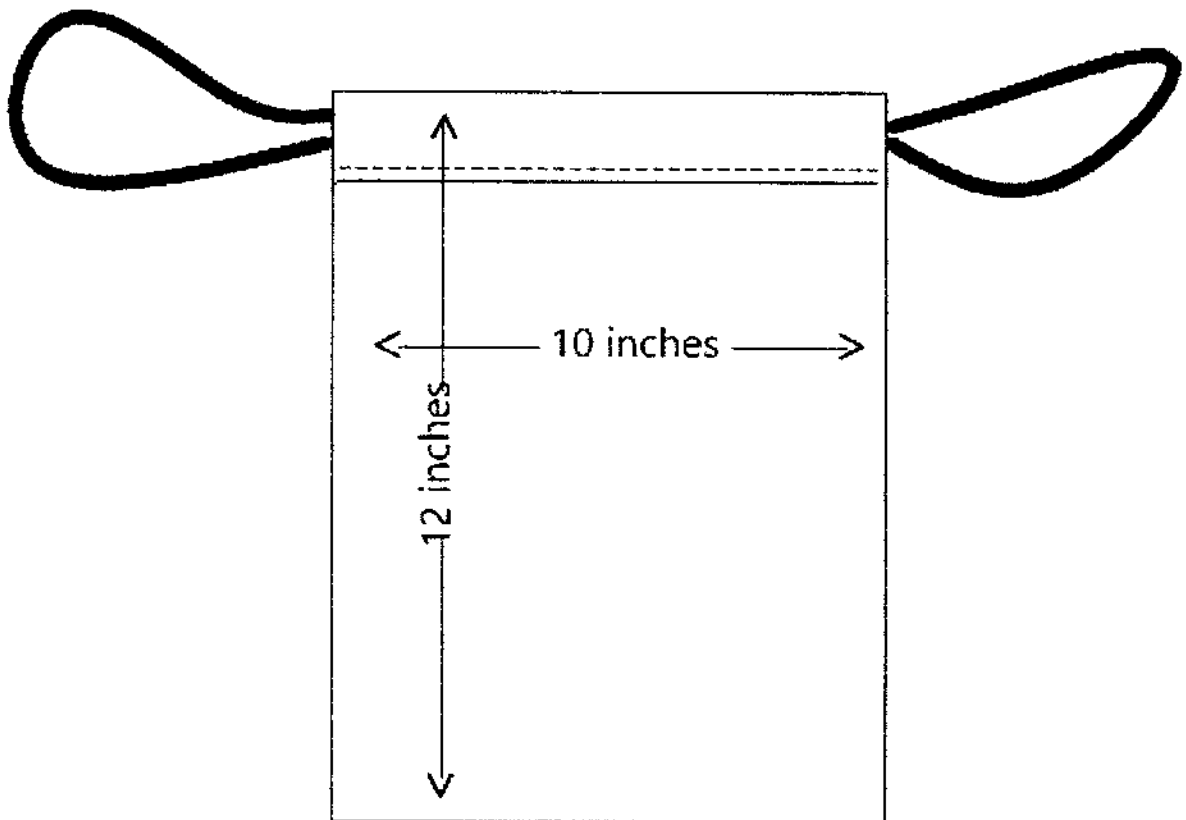
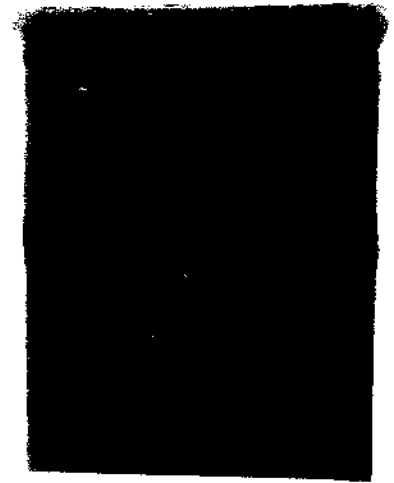

Wheelchair Bag, for Back:

Fabric:

Cut fabric piece 36" x 22". Sturdy fabric recommended.

Optional Lining; cut second piece of cotton or similar fabric.

Sewing Directions

- 1) Fold in half with right sides together (size now 18" x 21") and stitch the two side edges leaving edge opposite fold open.
(If you want to add a lining, repeat, and insert in bag.)
- 2) Hem open end with 1 inch hem and double stitch edges
- 3) Straps, cut piece of fabric 4 inches wide and 16 x 18 inches long. Fold like bias tape. Stitch open edges together. Cut strip so that you have two pieces, each about 8-9 inches long by 1 inch wide.
- 4) Fold each strap in half so you can position a strap on the inside seam of the bag. Stitch through all layers on each side to securely fasten straps.
(Example: stitch a square the size of your hem, then stitch an X in it.)

Pocket (Optional):

If you would like to add a pocket on the front, cut a piece of fabric 8" x 18". Hem top edge of pocket. With right sides together sew the bottom of pocket to the fold line of bag. Press and pin in place. Stitch a straight line through the pocket forming two compartments. Reinforce stitching. Then continue with sewing directions.

Top Closing:

At the top, sew in a 1 inch piece of sew on hook and loop (Velcro).

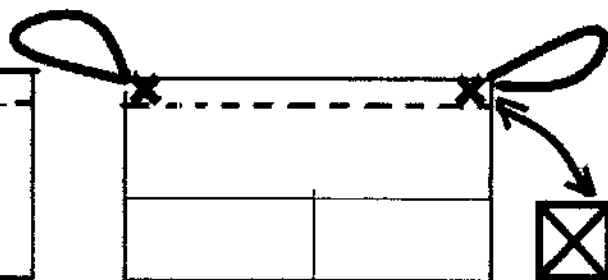
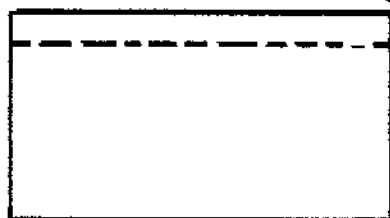
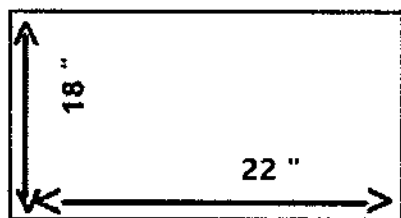
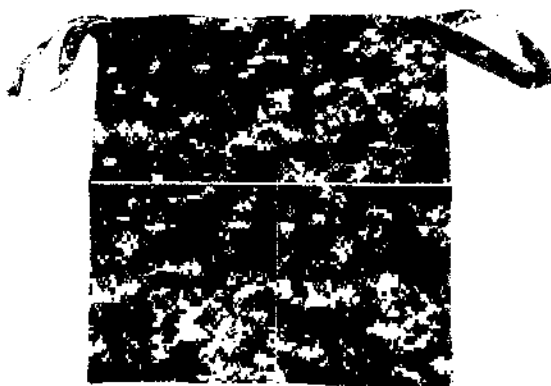

Walker Tote Bag

Fabric:

You need two pieces of fabric that are 14-15 inches wide by 43-53" long. Fabric can be identical or contrasting. Heavier fabrics are harder to work with but offer a finished product that is durable and able to hold heavier loads without sagging.

Notions:

- 6 inches of sew-on hook and loop tape (Velcro) cut in 3 inch pieces
- Thread

Sewing Directions:

Pin right sides together and sew all the way around, leaving a 6-inch opening large enough to turn tote right side out. Trim corners. Turn the tote right side out, press thoroughly so edges and seams lay flat. Use a chop stick or knitting needle to push the corners out so they are as square as possible.

Velcro Placement:

Mark the center of tote on the long edge by folding in half. The hook and Loop tape should be sewn five inches from center and 1 ½ inches from the side. See the diagram.

Edges and Pockets:

Fold up the ends of the fabric to make pockets on both sides. Measuring so that top of pocket is evenly placed from the center and covers the Velcro you stitched on. Approximately 5". Pin pockets in place and top stitch around the tote close to edge closing the opening you left to turn tote right side out.

Sew a straight line up the center of each pocket to form two smaller pockets. Be sure to reinforce stitching at top of pocket.

It's Finished!



Velcro Placement Guide

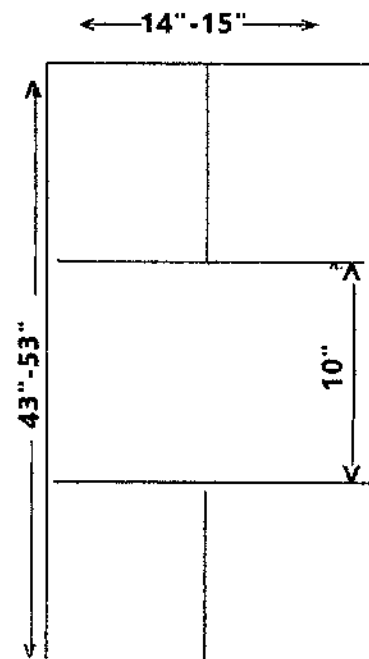
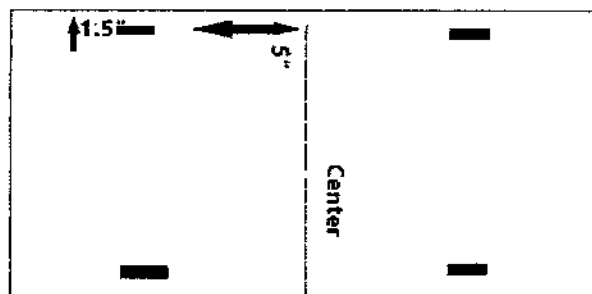

Child's Activity Bag/Supplies:

Fabric:

½ Yard of fabric or felt.

- Cut one piece that is 12 inches x 30 inches
- Cut two pieces that each measure 4 inches x 18 inches.

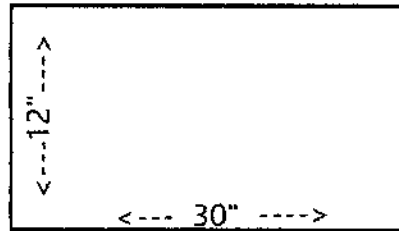

18"



Sewing Directions:

- 1) Fold 12 x 30 Inches in half (Measures 12" x 15").
- 2) With right sides together stitch the side seams using ¼ inch seam allowance.
- 3) Turn right side out and press.



Strap Handles:

- 4) Sew the 4" x 18" with wrong sides together, turn right side out, press.
- 5) Place on end of strap handle at top of bag 2 inches from side seam and pin in place. Repeat for the other end of handle being careful not to twist the handle
- 6) Flip the bag over and match handles to the first side and sew in place.
- 7) Zig Zag or stitch ¼ inch around top of bag.
- 8) Turn down ¾ inch around top of bag, press and top stitch to hold straps in place.

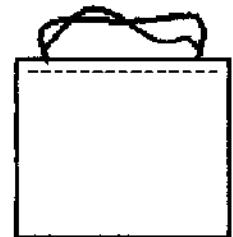
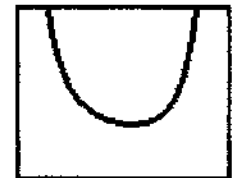

Children's Activity Items that can be included:

- Small Mini Books
- Stickers
- Word Search Pages/Books for Children
- Dot to Dot Puzzles
- Foam shapes (Self-adhesive)
- Notebook or Paper
- Coloring Pages or Books
- Non-toxic Colors
- Lacing Cards
- Homemade Mini felt board w/Shapes
- Ziploc Bags

Large Tote Bag

Fabric:

You need 5/8ths of a yard. A stiff twill or trigger fabric is best.

Cut one piece 18 inches wide and the width of the fabric. The fold will be the bottom of the bag.

Sewing Directions:

With right sides together, sew a half inch seam on each side. Then you want to box the bottom of the bag so that it is 6 inches wide.

Straps:

For straps you need 2 pieces that are 4 inches wide and 22 inches long. Fold these into 4ths and sew the long side of the fold to create your strap.

Top of Tote:

Fold the top of the bag under 1/4 inch and sew around the top of the tote. Then turn the top of the bag down 1 inch. Place the handles over this 1 inch seam. Place about 4 inches from each side seam. Sew around the top at the outer edge and at the inch folded down section so that you securely catch the handles.

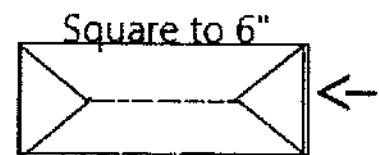
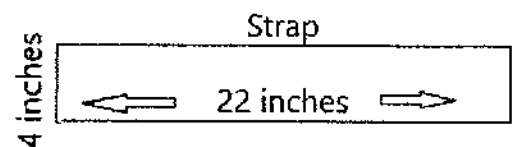
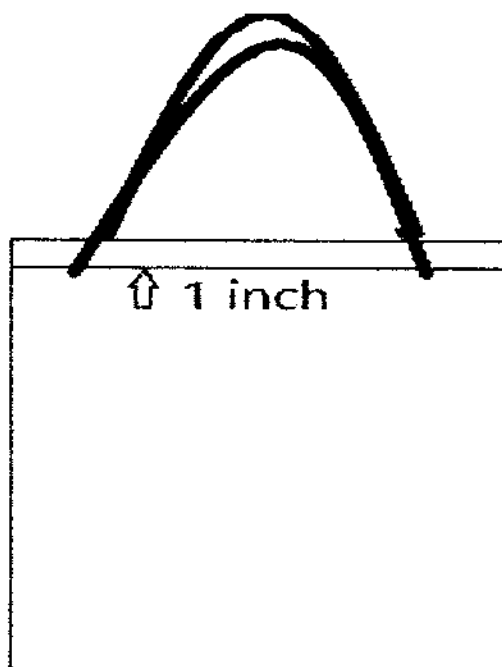
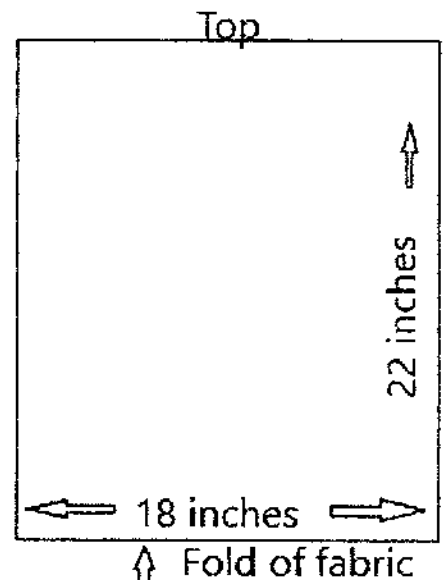

Tote

Family Bag:

These bags are provided to resident or Patient family members and supplied with personal products needed for extended stays

Fabric:

Use sturdy fabric, such as Trigger.

The finished size should be 16" x 16" with a 4" squared bottom. Create two handles or insert drawstring through the top hem.

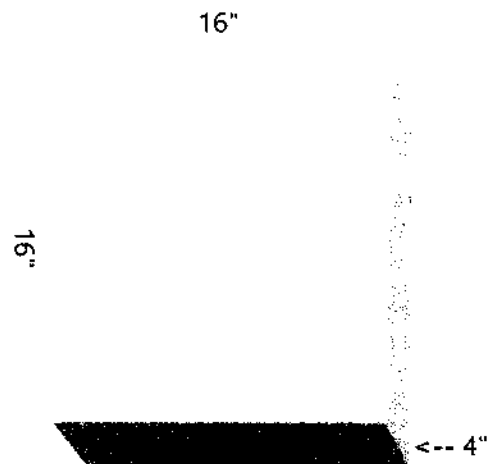

Cover-Up with Ties (for Clothes Protection):

Fabric:

Terry cloth towel works well for this.

Directions:

- 1) Fold the bath towel in half lengthwise. Cut a slit 7 inches from the edge of the towel. (a 7" plate makes a good pattern)
- 2) Fold the slit edges $\frac{1}{2}$ inch twice and hem each side. Be sure to back stitch over hem of towel.
- 3) Use seam binding to finish the neck and make ties. (Velcro can be used for closing also)

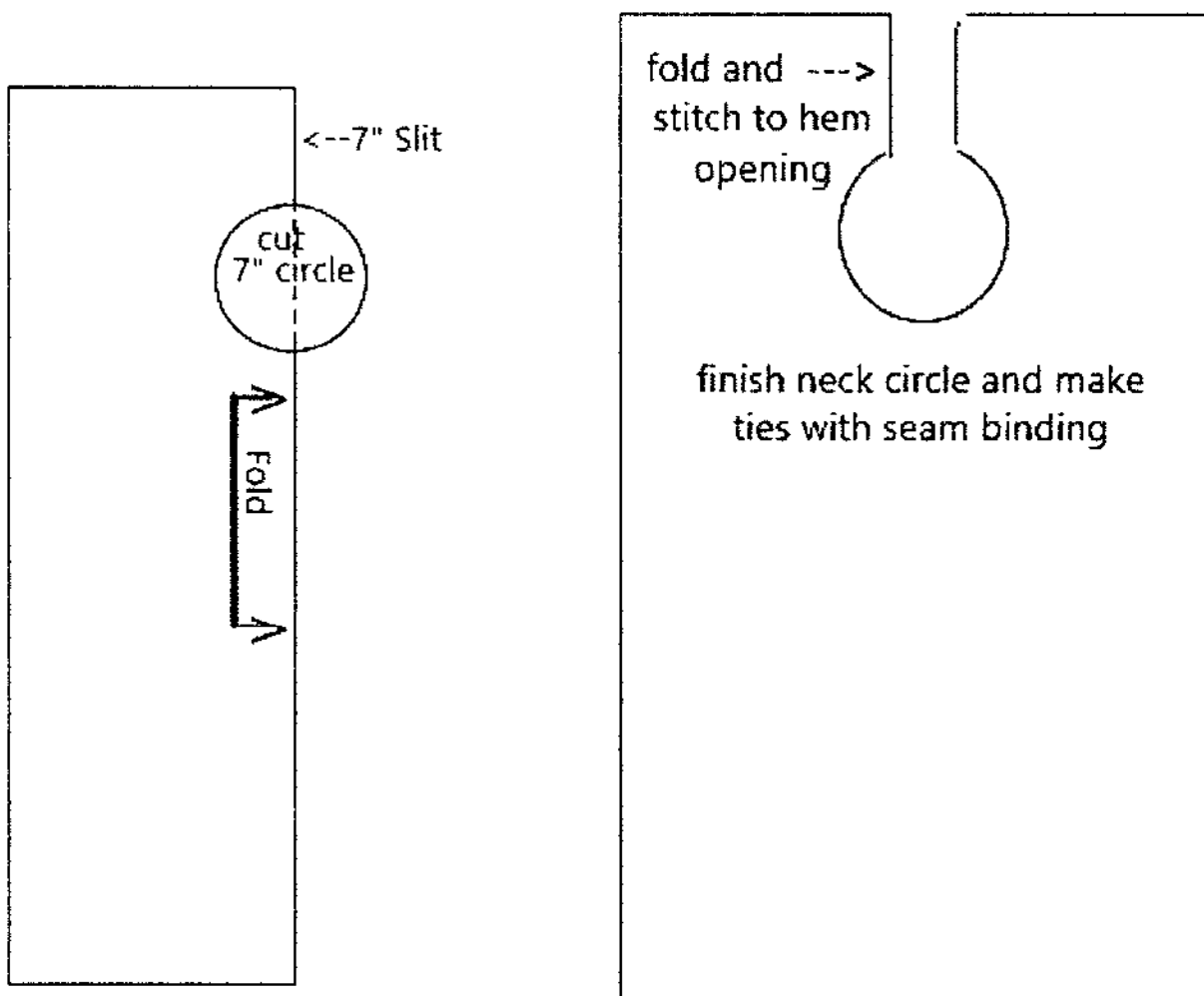

Terry Cloth or Fabric Cover-Up/Shirt Protector:

Double Layer

Fabric:

Terry cloth or other soft fabric a piece measuring 36" x 45" Cut 2 Pieces 18" wide by 39-40" long. Round corners. Cut out a 7" circle for the neck opening, with slit in the back.

Sewing Directions:

1) With right sides together, sew around leaving a 4"-5" opening to turn item right

side out.

2) Turn right side out, trim, and press. Stitch opening closed by hand, or run a top

stitch around the outside edge.

3) Sew on a 1" piece of hook and loop tape (Velcro) on the neck opening as shown.

Single Layer:

This same pattern can be used for a single layer cover-up/shirt protector. Use bias tape to finish edges.

(Note: Fergus Falls prefers not to have any Velcro or snaps for closing.)

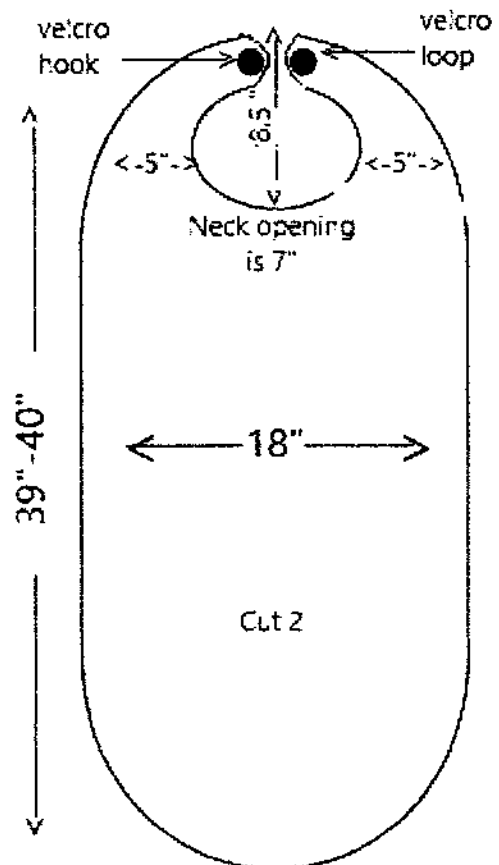
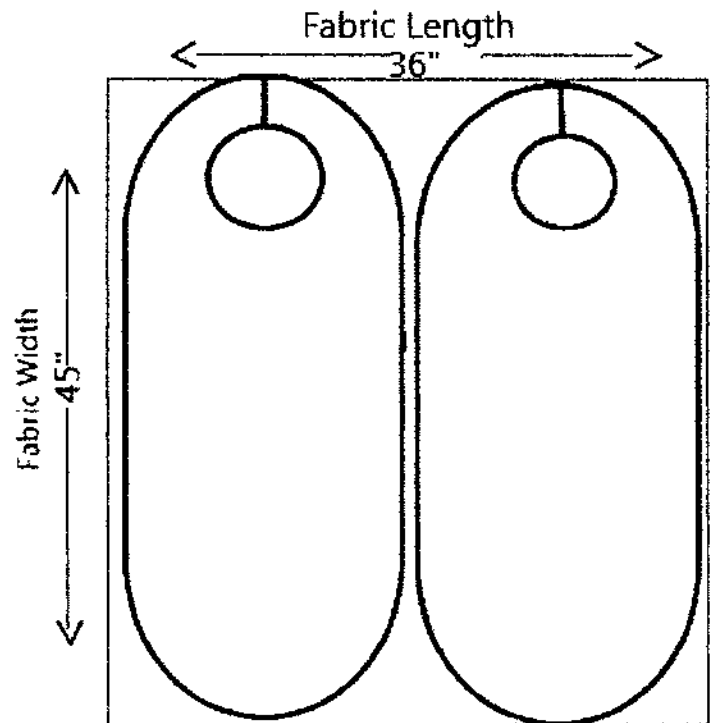

Patient Shower Cover:

Note:

This cover is used to provide the patient/resident who is confined to his/her wheelchair some privacy when being transported from their rooms to the shower facility, and back to their room. It covers the upper body and around the wheelchair frame.

Fabric:

Fabric should be poly-cotton or regular cotton. Dark colors are better as they are not as transparent as lighter colors.

Directions:

- 1) The finished size is two (2) yards long and 25" wide. The edges are to be finished by a rolled hem or serge and turn back once and stitch. Round two corners on the long side where you will place the 9" by 15" pieces from the next step.
- 2) Cut two pieces of fabric 9" x 15". Sew one on each side as illustrated in the diagrams. On this rectangle, stitch 4" piece of hook and Loop tape (Velcro) for fastening the cover together.

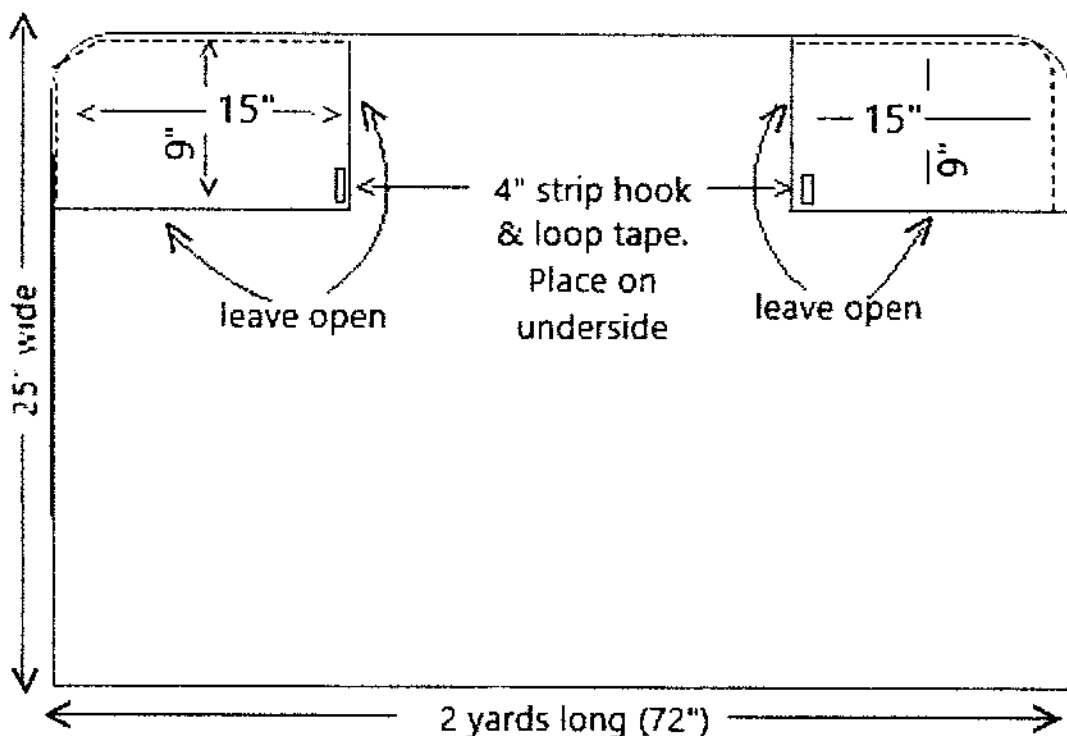

Pleated Face Mask:

Fabric:

For adult size mask, cut 1 fabric rectangle 16 inches long and 8 ½ inches wide. Cut 2 pieces of elastic, each 7 inches long.

Sewing Directions:

1) Fold fabric in half with right sides together. Sew along the 8 ½ inch width edge using 5/8-inch seam allowance. Leave a 3-inch opening in the center of this seam to create an opening to allow the mask to be turned right side out after sewing. Press seam open.

2) Pin one piece of elastic to each side of the mask, one end to the top corner and one end to the bottom corner sandwiching the elastic between the fabric.

3) Sew sides of the facemask, back stitching over ends of elastic to secure them.

4) Create three evenly spaced ½ inch pleats. Pin the folds in place, making sure all pleats are facing the same direction. Sew down each side to secure the pleats.

Note: When mask is worn, the pleats should open downwards to prevent any particles from collecting in the fold pockets.

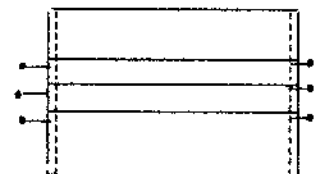
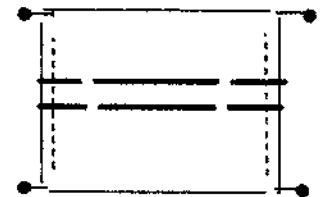
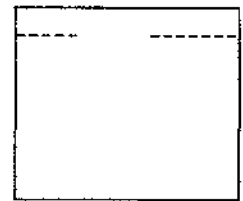
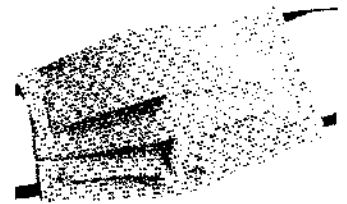
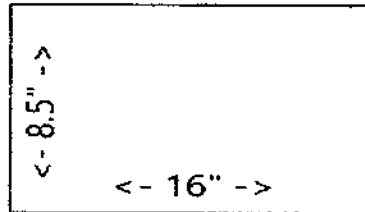

Face Mask Pattern:

Fabric:

1) Prewash all material on hot and dry to preshrink fabric as much as possible.

2) Cut 2 pieces for the mask and 2 pieces for the lining. Please add $\frac{1}{4}$ " to pattern for seam allowance.

3) With right sides together sew side A of mask and lining. Clip curve, press open.

4) With right sides of mask and lining together matching seams and edges, sew all around the mask leaving an opening on the bottom edge to turn mask right side out. Trim corners and curves so mask will lay flat.

5) Top stitch all around the mask $\frac{1}{4}$ " from edges closing the opening as you sew.

6) Fold the two sides in $\frac{1}{2}$ " and stitch forming a casing.

7) Insert 9" piece of thin elastic. Tie a knot and ease knot into casing to complete.

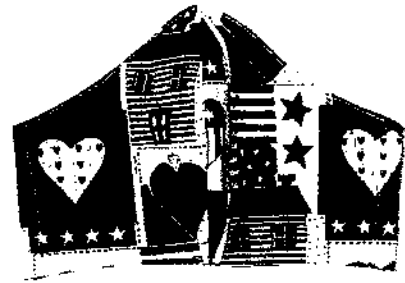
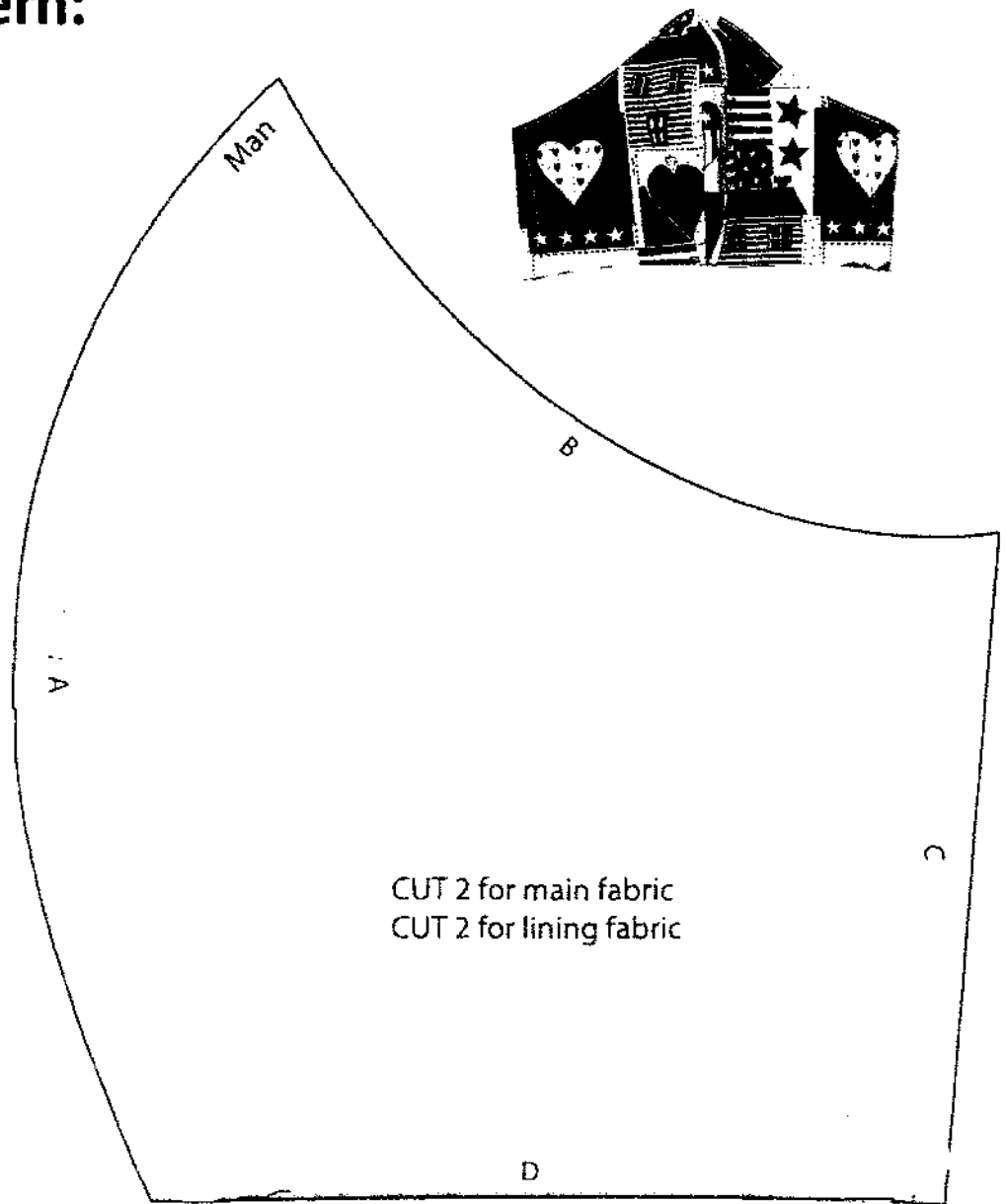

Urine Bag Covers:

Fabric:

Fabric for these bags should be washable and white in color. Fabric such as broadcloth or muslin can be used. Cut fabric at least 14" to 15" square and allow a ½" seam allowance. Allow for hem on tote design.

Cover with Snaps:

This cover has a finished size of a 13-inch square. It is fastened on two sides by snaps for easy access in covering and removing for laundry. The third side is a fold or could be a seam. The fourth side is left open.

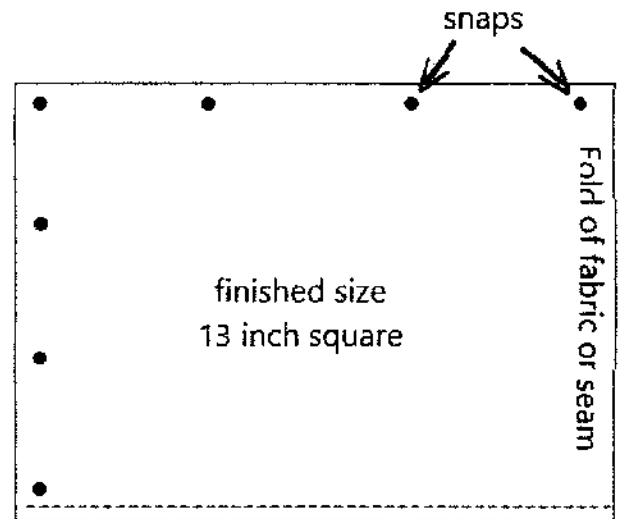

This side is hemmed but left open

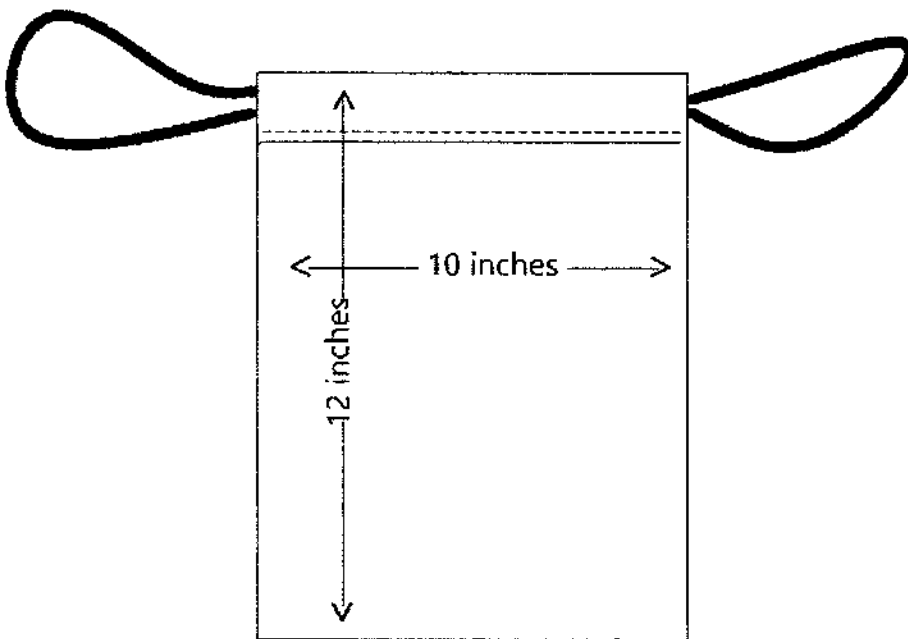

Tote Style Cover:

This cover uses a 13-inch tote bag with ties that are at least 6 inches wider than the square bag. 36-inch shoelaces are a suggestion for ties or a white twill tape.

Note: Please be sure to check with the facility to see if they use these or which style they prefer.

Neck Pillow:

Fabric:

½ yard of fabric plus ½ yard for contrasting or 2 pieces 18 x 20 inches. Choose a soft fabric such as flannel or cotton. Bright or patriotic colors are cheerful.



Sewing Directions:

- 1) With right sides together sew pieces together leaving a 5" opening at the top.
- 2) Clip inside curve around (neck) being careful not to clip your stitching.
- 3) Stitch inside curve (around the neck) again to reinforce.
- 4) Turn right side out and press.
- 5) Stuff with polyester fiberfill till very firm. Hand stitch closed

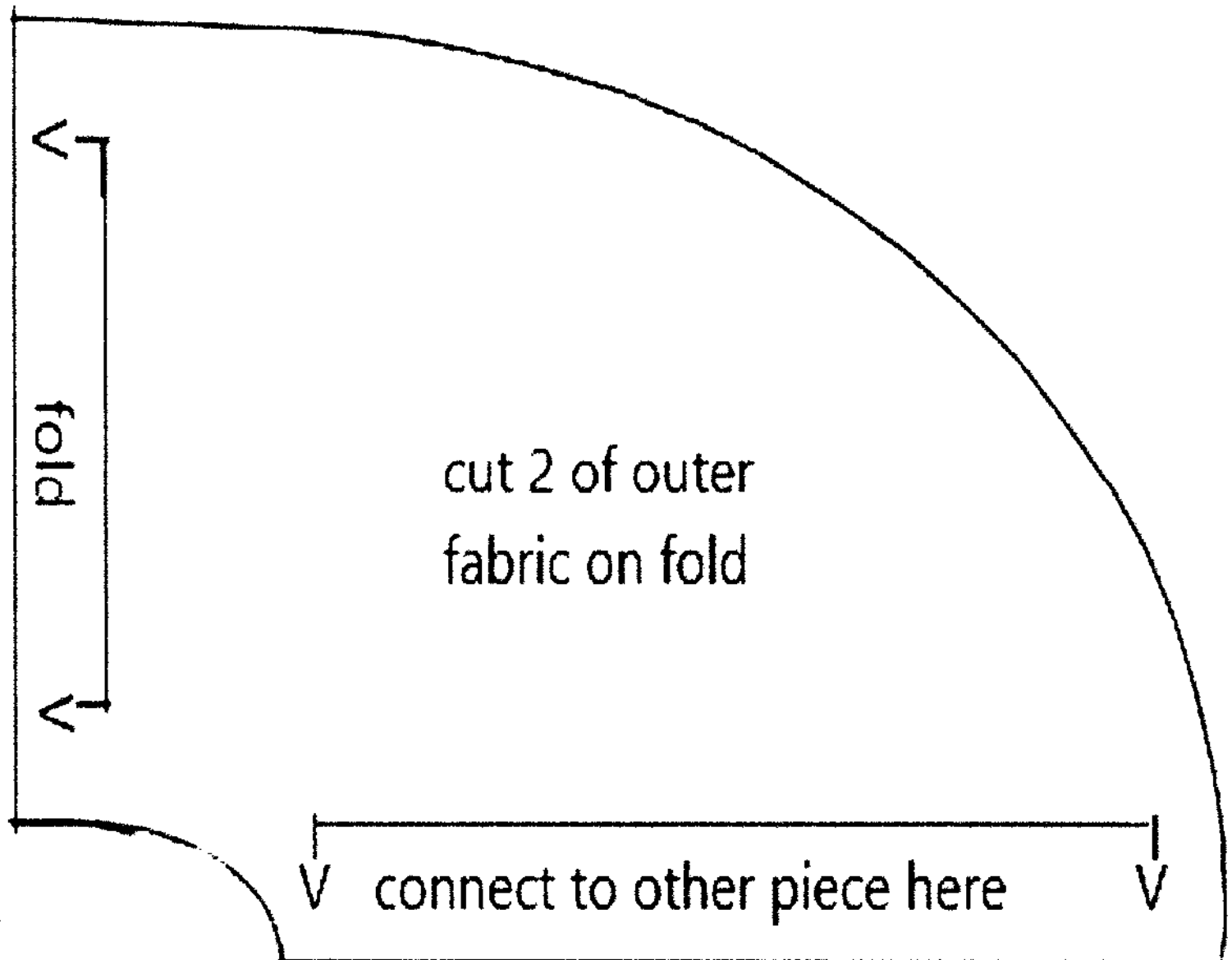

Neck Pillow(continued)

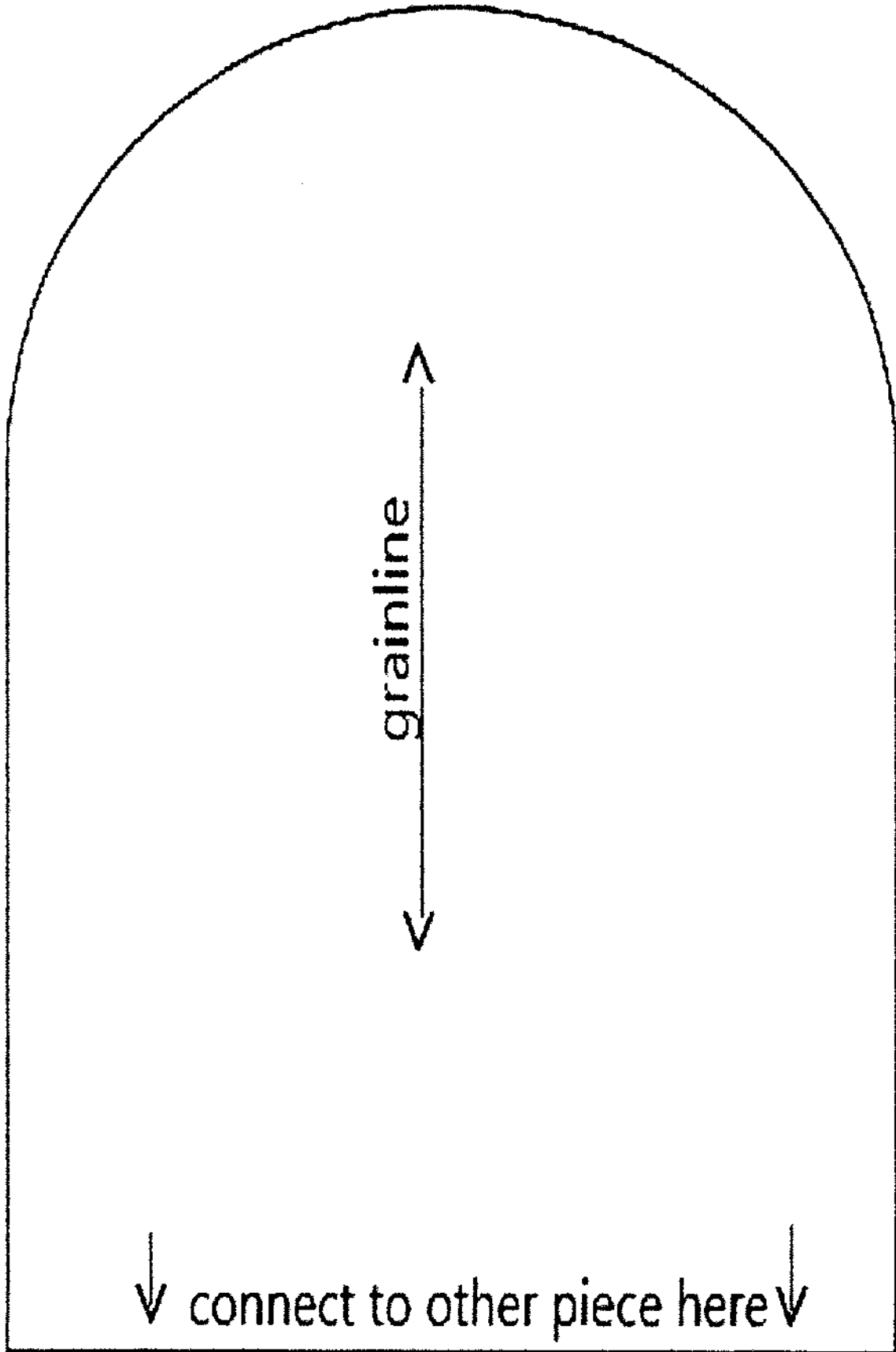

Heart Pillow:

Fabric and Notions:

You need $\frac{3}{4}$ Yard for each side. Matching or contrasting.

(Total 1 $\frac{1}{2}$ Yards)

Polyester fiberfill. Use $\frac{1}{4}$ inch seams. Finished size is approximately 18" x 18".

- 1) Attach pattern pieces together. Arrows will not match up.
- 2) Cut 1 from main fabric and one from contrasting fabric. (Cut 2 total)
- 3) With right sides together stitch around heart leaving a 3–4-inch opening on one side.
- 4) Trim and clip curves
- 5) Turn right side out and press.
- 6) Stuff with polyester fiberfill till firm.
- 7) Hand stitch closed.

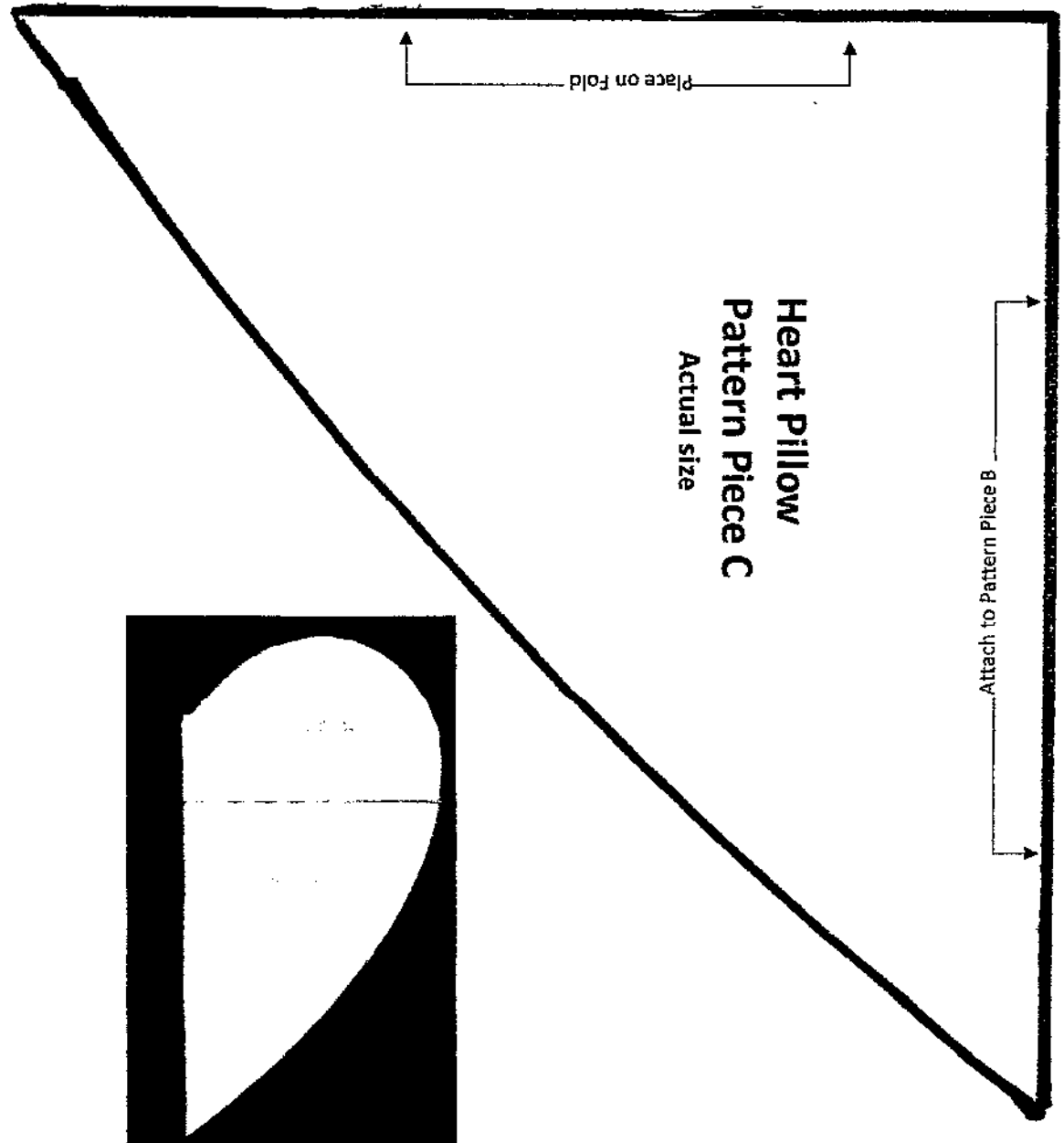

Note: A 50 oz bag of polyester fill will do about 3 pillows.

Heart Pillow (continued):



Heart Pillow (continued):



Cross Body Messenger Bag

10 x 12 Cross Body Messenger Bag with Velcro flap and front pockets



Fabric:

Front and Back body & Lining: cut 4 - 11" x 13" (round bottom corners)

Flap: cut 2 - 9" x 13"

Gusset: cut 2 - 2" x 34" (one main fabric & one for lining)

Pocket/Lining: cut 2 - 8" x 13" (round bottom corners)

Strap: cut 1 - 3" x 60" (or longer)

Lining: Front and Back: cut 2 - 11" x 13" (round bottom corners)

Notions:

- 2" piece hook & loop tape (Velcro)
- Thread

Sewing Directions:

- 1) With right sides together, sew top edge of pocket pieces. Turn and press. Mark center and stitch from top to bottom forming two pockets. On the pocket, about 2" from top of pocket, center a 2" piece of Velcro. Pin pocket to front piece of messenger bag.
- 2). Sew the front of bag to gusset easing fabric around edges. Sew back piece of bag to the gusset. Do the same with lining pieces.
- 3). On piece that will be inside of flap, center and sew the Velcro piece about 2" from the edge with rounded corners. With right sides together sew flap pieces together, trim, turn and press.
- 4). With right sides together, sew edges of crossbody strap together, turn and press. Attach the strap to the gusset securely. Make sure strap is not twisted.
- 5). Sew the Flap piece to the back of the bag.
- 6). With rights sides together place the bag section inside the lining of bag. Sew the edges together starting edge of the gusset across front of bag leaving the edge with the flap open. Turn and press.
- 7). Along the flap/body edge, turn in seam and top stitch to close.

